

RCL – For Excellence In Reliability

RCL



**Reliability
Consultancy
Limited**

Proud to
be members
of the

National
Microelectronics
Institute



Bespoke Training

Classroom / Virtual Classroom

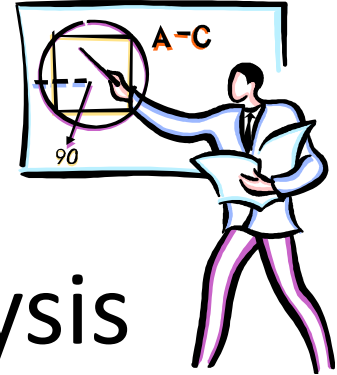

- Design for Reliability / Analysis
- Theory and Practice of Stress Tests
- Knowledge Based Qualification
- Real Environment based Assurance

Consultancy

Insightful approach based on
25 years experience :



- Troubleshooting
- Failure Analysis Consultancy
- Design to Manufacture

From Design to Manufacture

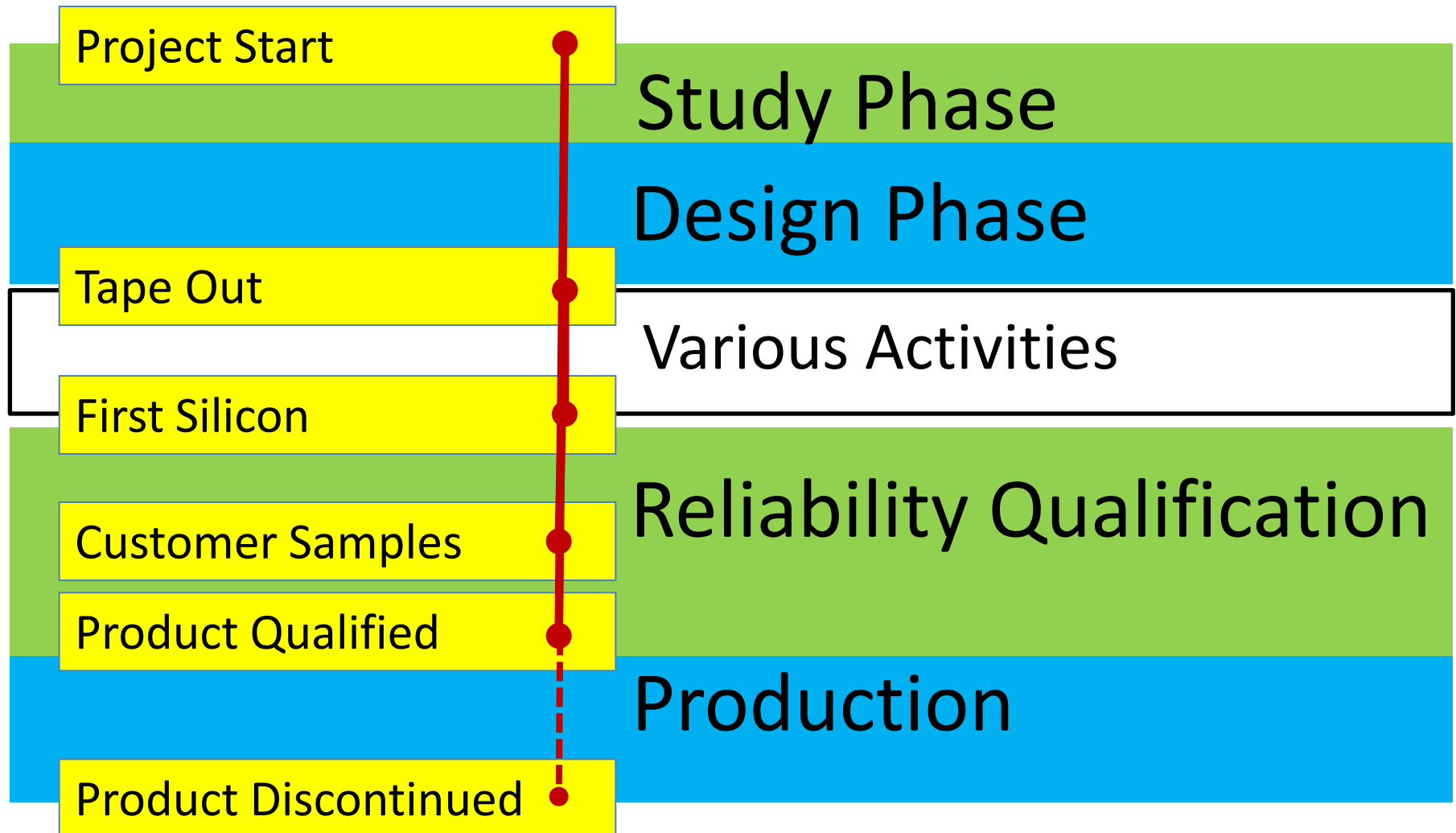

Knowledge Based Approach

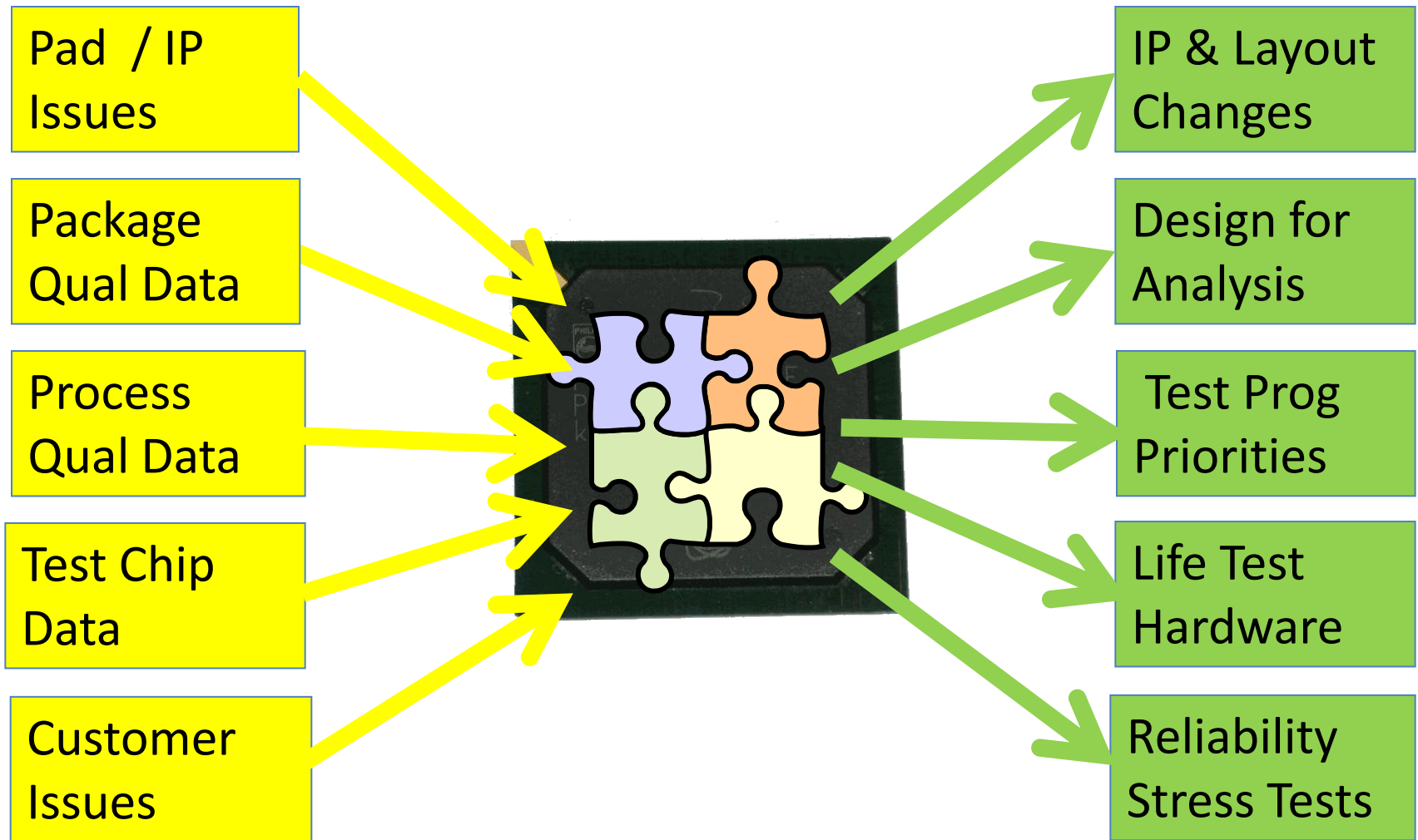

Real Environment Based Assurance

Relevant to Application Conditions

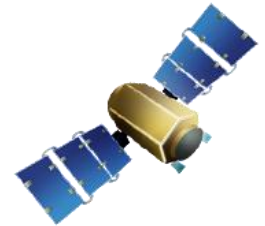
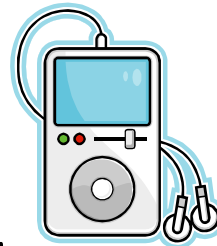

- Transport / Handling
- Power On Hours / Field Lifetime
- Power Cycles / %RH / Temp Range
- T_j / Operating Voltage

ESD Improvements

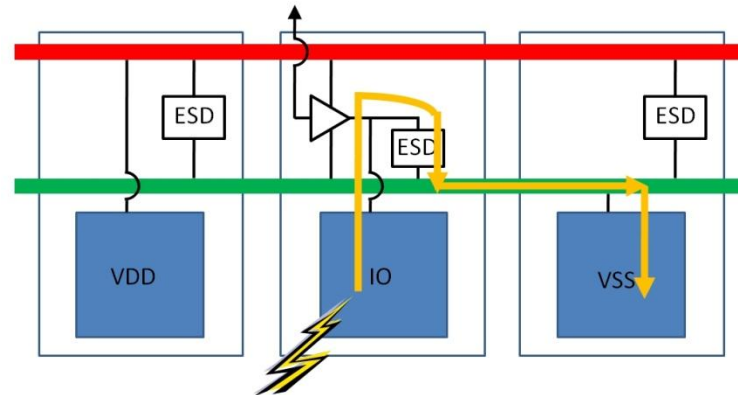
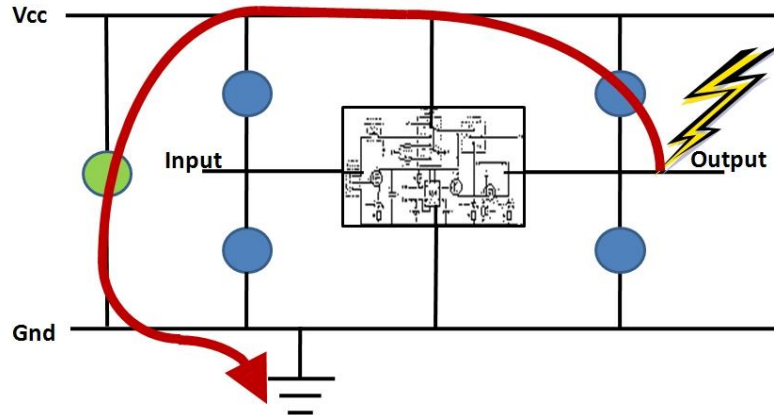
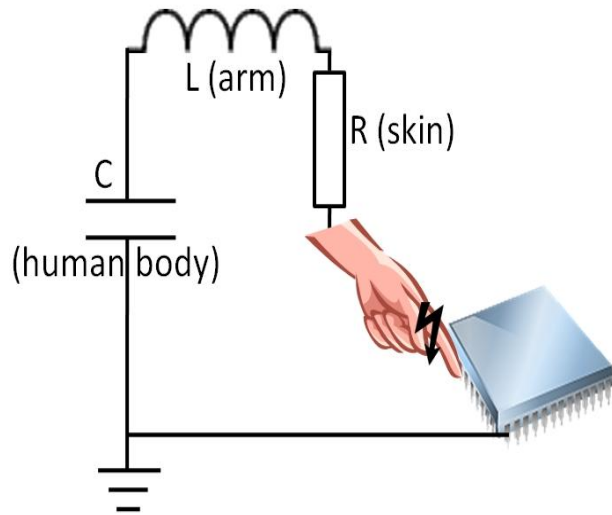

Contact Details

Contact Stephen Meats on



+44 (0)1794 321105



+44 (0)7825 611021



web-queries@rcl-reliability.com